TWT® IonGuard Disinfection & Purification System

Pool • Spa • HVAC Water Treatment & Conditioning

Commercial/Industrial Model#

TWT-5C8-277-0.5 Amp • TWT-5C8-278-1.25 Amp • TWT-5C8-279-2 Amp

OWNER APPLICATION & INSTALLATION MANUAL

The TWT® systems will give many years of service if sized and installed properly.
Please read all instructions carefully before assembling the system.



SEE PAGE 9-10: INSTRUCTIONS FOR THE USE OF TWT® DEPOSIT CONTROL TECHNOLOGY

If you have purchased model#

TWTDCI-5C8-377 • TWTDCI-5C8-378 • TWTDCI-5C8-379

integrated deposit control and ionization treatment system

Note: IonGuard operational instructions are the same for all listed treatment systems
Do not discard operating manual, keep in equipment room for reference



TABLE OF CONTENTS

Section 1: System Description

Section 2: Operating Principals

Section 3: Installation

Section 4: System Installation Overview

Section 5: Connection of the Ionization System to the Connecting Piping

Section 6: Connection of the Ionization System to Remote Control System

Section 7: Connection of the IonGuard System to Electrical Power

Section 8: Steps to Put the IonGuard System in Service

Section 9: Adjusting the IonGuard System

Section 10: Replacing the Ionization Electrodes

Section 11: Trouble Shooting: IonGuard System

Section 12: Trouble Shooting: TWT Deposit Control Technology

Product Warranty / Performance Warranty (90 Days)

To find out even more about us, and how we can help you, contact us at: Email: info@triangularwave.com

Visit Triangular Wave Technologies, Inc.'s comprehensive website,
the valuable technical resource for all involved in water and fluid management...

WWW.TRIANGULARWAVE.COM

Bringing You The best in Fluid Management Solutions

SECTION 1

SYSTEM DESCRIPTION

The Triangular Wave IonGuard Purification System is a compact, self-contained system to kill bacteria and algae in the water system.

The IonGuard main components are:

- Power Supply/ Electronic Control Unit
- Ionization PVC "T-Housing" (Schedule 40 PVC)
- Copper/Silver Ionization Electrodes
- Power cord, electrical wires, and extra fuse.
- Copper Test Kit

Please Note: See page 9-10

For maximum efficiency, the Triangular Wave IonGuard Purification System should be installed with the Triangular Wave Deposit Control System.

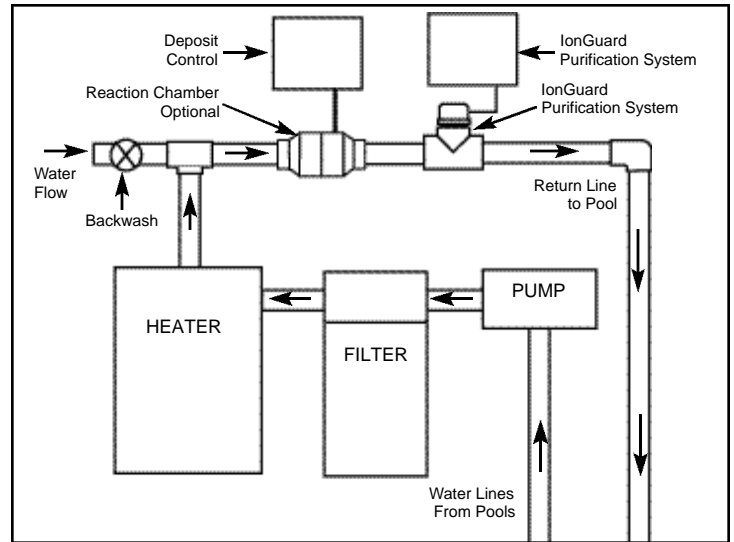
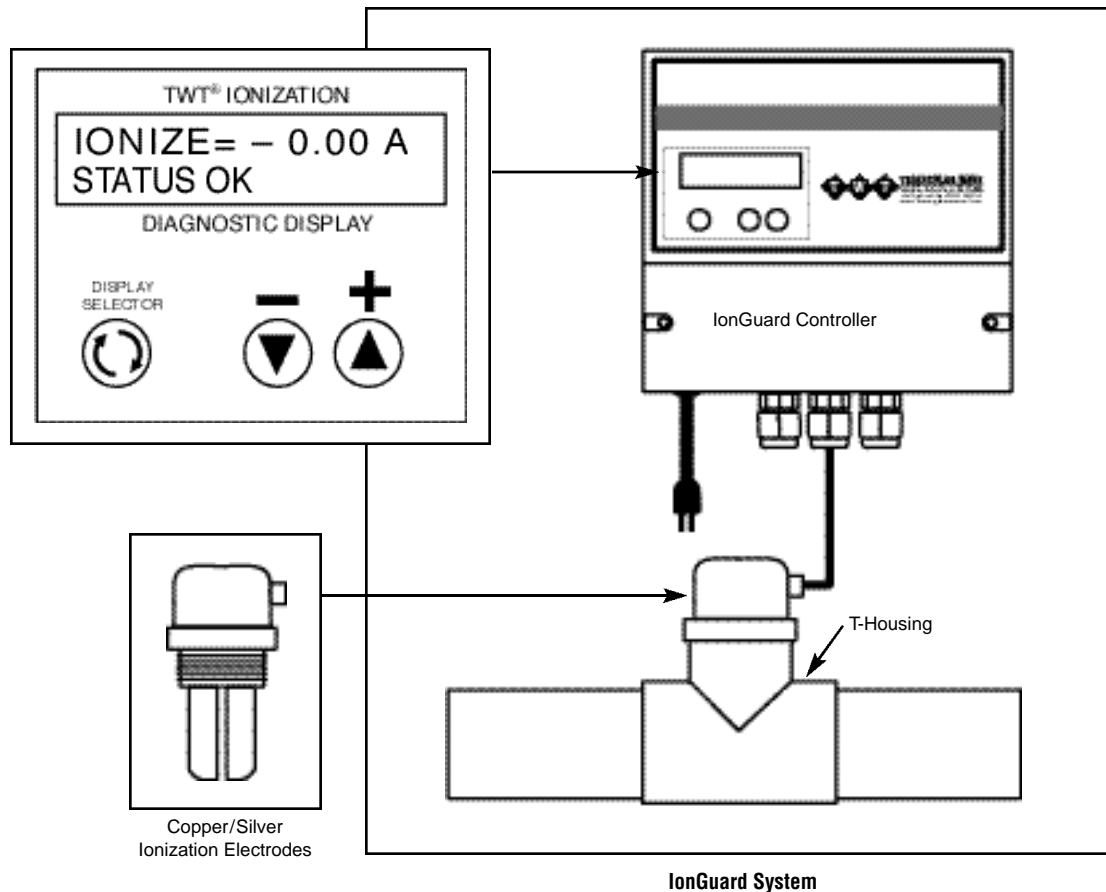

Diagram A. System installation overview
Not included: Recommend GFI be installed.



SECTION 2

OPERATING PRINCIPLES

The Triangular Wave IonGuard Purification System disinfects water through a process called ionization. That process utilizes a low voltage direct current [DC] to place precise and minute amounts of copper and silver ions into water systems. Copper ions kill algae and silver ions kill bacteria. An ion is merely an electronically charged atom or group of atoms. An atom acquires this charge by gaining or losing electrons. Negatively charged electrons are one of the three major subatomic particles; the others being protons, which have a positive charge, and neutrons, which have no charge.

Ions in the Triangular Wave system are positively charged; algae, bacteria and other particles in the water are negatively charged. The positive to negative attraction allows the ions to attach to the organisms, penetrate their cell walls and kill them.

The IonGuard Purification System is an electrolytic copper/silver ion generator. The system units contain specifically cast copper/silver alloy electrodes. These electrodes are mounted in a PVC housing designed specifically for easy access.

When the system is used in conjunction with a filter, the dead bacteria with the silver ion attached to it will be large enough for the filter to remove. Normal filter backwashing will then remove the dead particles.

The criteria for copper and silver in water are as follows: The EPA standard for drinking water is 1.0 ppm (parts per million) maximum for copper and 50 ppb (parts per billion) maximum for silver. The system

is programmed so that a water test showing 0.25 ppm to 0.35 ppm copper automatically provides the proper ratio of silver. This will produce drinking water quality in any water system treated. The system requires no chemicals in their function of controlling algae and bacteria.

A "current source" generator powers the IonGuard Purification System. "Voltage source" generators power other ionization units. In all ionization units, copper and silver ions plate off of the electrodes and enter the water. Over time, the electrodes will become smaller, and the gap between the electrodes will become larger. The current source generator will automatically compensate for the change in gap size; while the voltage source generators must be manually inspected and adjusted. The current source generators on the Triangular Wave IonGuard System offers trouble free operation.

We recommend that the IonGuard Purification System be installed downstream of a Triangular Wave Deposit Control System. The Deposit Control will keep the IonGuard System electrodes free of scale and other deposits for more effective results. And, at the same time, the Deposit Control System will help eliminate scale and biofilm deposits through the entire water system. (see diagram A Page 1)

Without the Triangular Wave Deposit Control System in place, the ionization electrodes may develop either a layer of scale or oxidation. In either case, it is necessary to periodically clean the electrodes with an acid solution. The Deposit Control System Reduces the need for periodic cleaning.

SECTION 3

INSTALLATION

In general, installation of the IonGuard System should follow these seven steps: Select a location on the recirculating water line to insert the Ionization PVC "T-Housing". The location should be downstream of the pump, filter, and Triangular Wave Deposit Control System. **[Recommended]**

- **Select a location on a wall to install the Power Supply/Electronic Control Unit. The IonGuard System installation kit includes 15 feet of wire in a conduit/electrode wire assembly, which should allow adequate flexibility when installing to Power Supply.**

- **Install the two isolation valves (not included, in those cases where equipment is below water level) and the PVC "T-Housing".**
- **Install the Power Supply/Electronic Control Unit.**
- **Install the Copper/Silver Ionization Electrodes into the PVC "T-Housing".**
- **Connect the conduit/electrode wire assembly between the Power Supply and the Ionization Electrodes.**
- **Connect the Ionization Power Supply to electrical power.**

INSTALLATION

The Ionization Purification System should only operate when water is flowing through the recirculating pipes; that is, when the pump is operating. Two options are available to insure the Ionization System and the pump operate together.

- The AC power cord may be wired across the pumps power supply; or
- The AC power cord may be plugged into a 110/220 VAC outlet, and the “standby” feature may be connected to a flow switch or a timer switch.

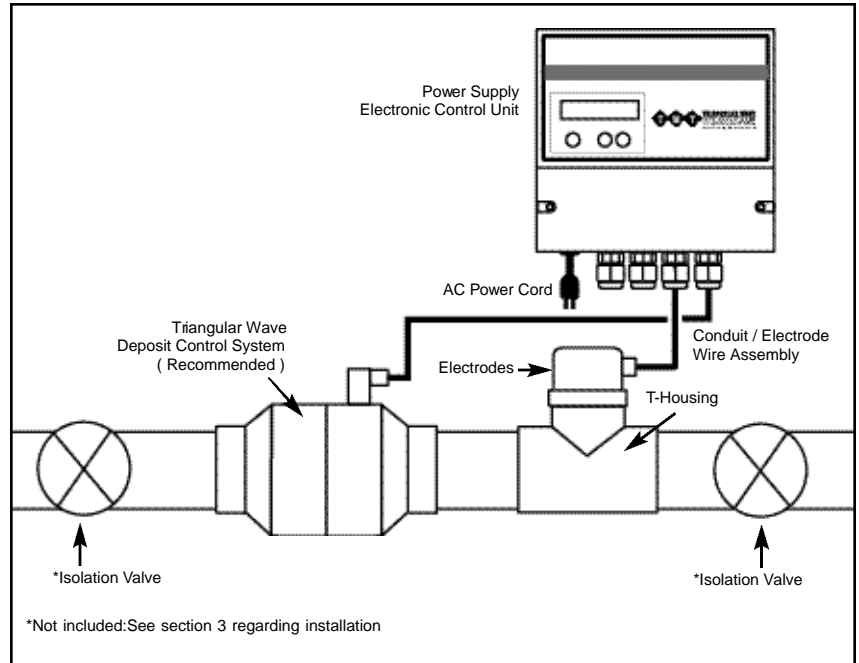

Figure 1: IonGuard Purification System

SECTION 4

SYSTEM INSTALLATION OVERVIEW

Installation of the PVC “T-Housing” is site specific. For best results, the Triangular Wave IonGuard Purification System should be installed downstream of the pump, the filter, and the Triangular Wave Deposit Control System.

The connecting piping should include isolation valves upstream and downstream of the PVC “T-Housing” to facilitate replacement of the Copper/Silver Electrodes.

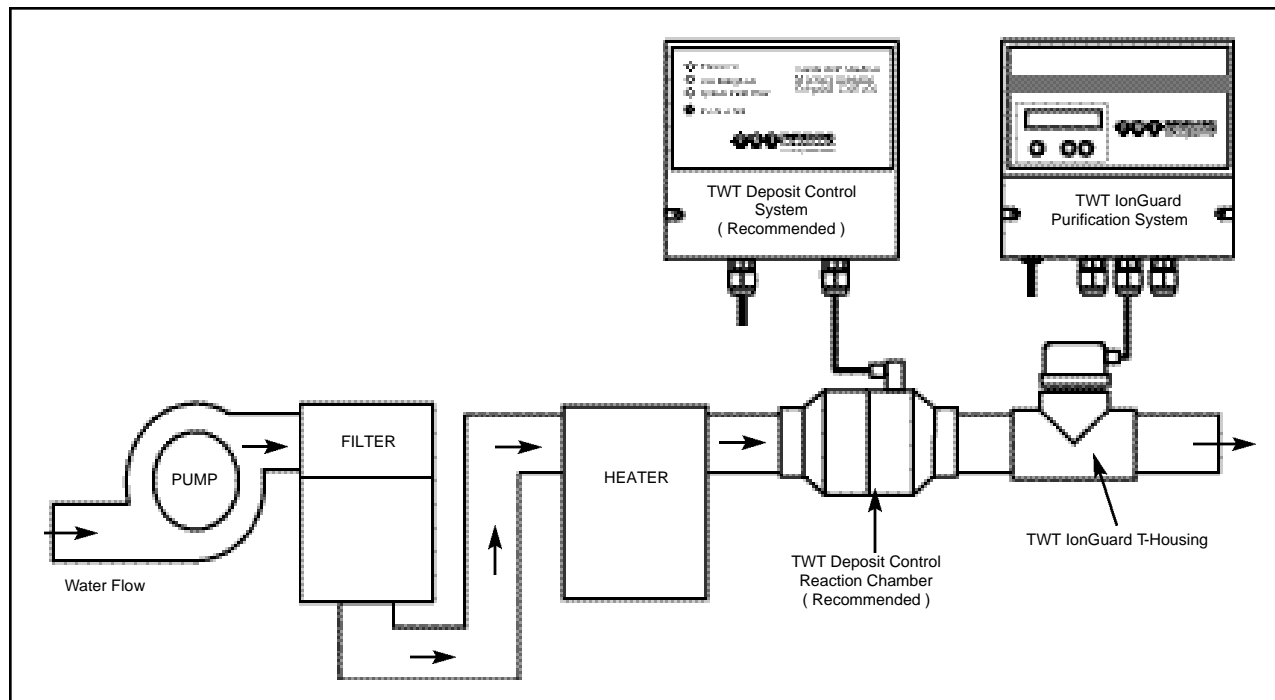

Pumps, piping, fittings, valves, and other material needed to and from system owners responsibility

SECTION 5

CONNECTION OF THE IONIZATION SYSTEM TO THE CONNECTING PIPING

The PVC "T-Housing" should be fitted with appropriate coupling fittings to allow it to be connected to the

pipng. All fittings should be tested for water tightness.

SECTION 6

CONNECTION OF THE IONIZATION SYSTEM TO REMOTE CONTROL SYSTEM

The IonGuard System maybe connected to a remote control timer switch or flow switch. The connection is made via a low voltage circuit. If the remote circuit is closed, the Ionization System will be in normal operating mode. If the remote control circuit is open, the Ionization System will be in standby mode (pump is off and the ionization system is not energized).

If there is no remote control circuit available, then the jumper wire provided with the Ionization system should be left in place on the two interlock standby terminals. If the jumper wire is removed, the Ionization system will go to standby mode.

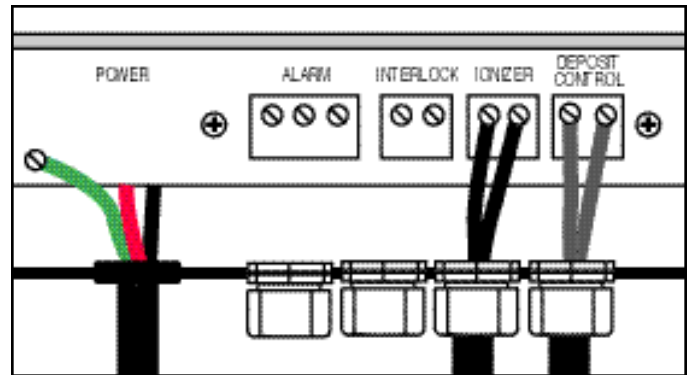

Low Voltage Circuit Connections

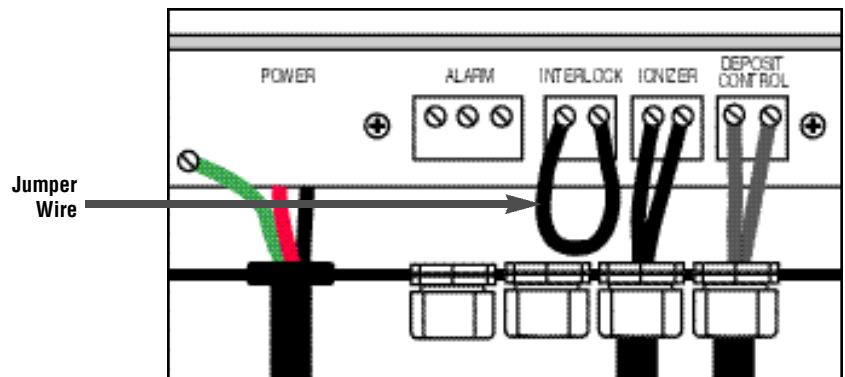

Jumper cable on remote control contact terminals

SECTION 7 CONNECTION OF THE IONGUARD SYSTEM TO ELECTRICAL POWER

The IonGuard Purification System should only operate when water is flowing through the recirculating pipes; that is, when the pump is operating. Two options are

available to insure the Ionization System and the pump operate together.

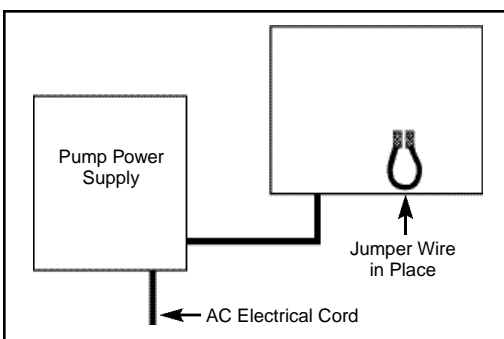

The AC power cord may be wired across the pump is power supply; or

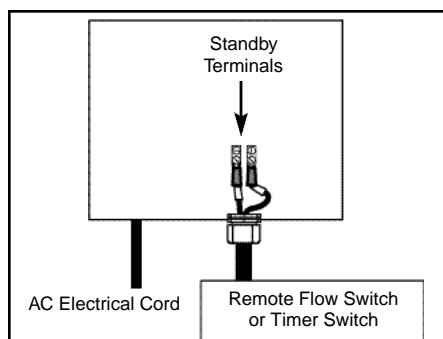

The AC power cord may be plugged into a standard 110 VAC outlet, and the "standby" feature may be connected to a flow witch or a timer switch.

The TWT[®] controller has a universal power supply. The controller is shipped with a North American 10A/125 VAC Cordset. The user can cut off the connector and install the desired connector or disconnect the cordset and install the appropriate cordset.

SECTION 8 STEPS TO PUT THE IONGUARD SYSTEM IN SERVICE

The following steps should be followed when placing the IonGuard system in service:

1. **Connect the system to the power source.** (See Section 7)
2. **Remote contacts for standby operation should be closed or the local jumper wire should be attached to the standby terminals.**
3. **Turn on power switch, the following should result:**

- Display will show **STANDBY** for two seconds.

IONIZE= - 0.00 A
STATUS

- Display will then show the current level set by the **Display Selector Control Button**. (see figure A)
- Polarity indicator will show PLUS or MINUS.

IONIZE ERROR

4. **Disconnect the jumper wire or open the remote control circuit.** The following should result:
 - Display will show

IONIZE= - 0.00 A
STANDBY

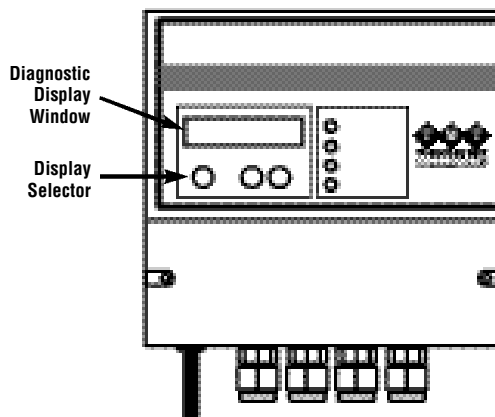

Figure A

SECTION 9 ADJUSTING THE IONGUARD SYSTEM

Read Copper Test Kit Instructions

Be sure to read, understand, and follow all of the operating instructions for your copper and other test kits. To minimize your overall operating costs while maintaining proper disinfection levels, you will need correct information from the test kits. See test kit recommendation under Trouble Shooting Guide.

Adjust the Control Unit

Several steps must be followed to adjust the Control Unit to achieve the proper copper level (0.25 to 0.35 parts per million). Start the system by pressing the power button to ON (operation is indicated on the diagnostic display window) and the selector to 50% power level. The percentage will be displayed on the alpha numeric display.

Using the copper test kit provided, test the copper level twice per day in the morning and evening. It should take no more than several days to achieve the proper copper level (0.25 to 0.35 ppm). When the proper level is reached, press the down button to approximately 20% power level.

Copper ions do not dissolve or evaporate. They combine with microorganisms in the water and kill the microorganisms. It is important to operate the control unit at the proper power level. With some

variation, operating the control unit between 10% and 30% power level should maintain the proper disinfection (copper) level of 0.25 to 0.35 ppm. The exact setting will vary pump run time, size of system, and other site specific conditions.

Once the proper copper level is reached, only weekly testing of copper levels will be necessary.

Proper Copper Ion Level

Proper ion levels in your system should be 0.25 to 0.35 ppm.

If the copper level exceeds 0.5 ppm turn the unit off until the copper level drops below 0.4 ppm.

- **Algae Growth - 0.0 to 0.2 ppm**
- **Ideal Ion Level - 0.25 to 0.35 ppm**

To use the Diagnostic Display window:

- Two pushes on **Display Selector** to view diagnostic window

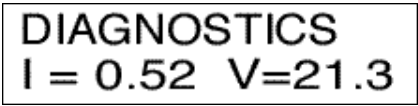

- The default window, will then display "Electrodes Worn" when the controller has reach the maximum voltage and can not provide the "set" current.

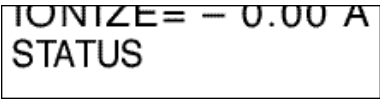

I= Current in electrodes

V= Electrode Voltage

- When V= (between 23 or 24 volts), indicates controllers maximum value.
- Maximum value will indicate electrodes worn and spare electrodes should be made available.
- When the current in electrodes (I) is displayed and when the value is below an acceptable level, electrodes must be replaced.

Use the following steps to change the ionization electrodes:

- 1. Shut off power to all systems**
- 2. Shut off water**
- 3. Remove protective cap from electrode were leads**
- 4. Disconnect electrode wire leads**
- 5. Unscrew electrode housing from reaction chamber**
- 6. Remove depleted electrodes**
- 7. Install new electrodes per the following procedure:**
 - Wrap electrode housing threads with at least three wraps of teflon tape
 - Screw electrode housing into PVC " T-Housing"
- 8. Turn on power to all systems**
- 9. Turn on water to test for leaks**
- 10. Turn off power to all systems**
- 11. Reconnect electrode wire leads**
- 12. Replace protective cap**
- 13. Turn power on**
- 14. Check power supply display for proper indicator**

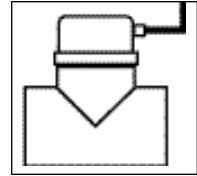

IonGuard PVC " T-Housing"

Notes

A large rectangular area with horizontal lines for taking notes.

The TWT IonGuard controller has a diagnostic display, this is accessed by two pushes of display selector. The diagnostic display window has the following listings, describing the content and their meaning:

DIAGNOSTICS
I = 0.52 V=21.3

- Each time the “selector” is operated the display will “page” to the next display. This new page will remain open for a short while so that the operator can adjust the selection item if desired. The unit will close the page if no action is taken.
- The system is digital. The adjustments are made with the **up and down** push buttons. The selector push button is used to display the correct page which allows this adjustment.

The ionization control has an interlock that must be closed for the ionization to be on. This provides for the control (on/off) of this circuit. The circuit may be controlled by this contact or the AC power may be switched on/off. The controller will be shipped with a **SHORT** in place on these terminals (see section 6).

IONIZE= – 0.00 A
STATUS OK

When the ionization contacts are OPEN the display will be:

- The numbers will indicate the current the unit is providing. This will be the same as the set when the controller and the water conditions permit. If the unit can not meet the set values it will display output current that it is providing. (see section 9)
- Standby: This indicates that the ionization is **OFF** and in a standby status.

IONIZE= – 0.00 A
STANDBY

When this circuit (interlock) is completed (shorted) the display will be:

- Ionize 000%–Status OK
- Status OK indicates that the ionization is ON and in service.

The ionization control is a current controller. The desired current is set on the display. The output voltage will increase to achieve the requested current. The controller has been engineered with a maximum output voltage of 24 vdc. When this voltage can not provide the set current/ value, the unit will go into alarm.

To set the desired current you must select the set current display (1 push of display selector).

- Push the **up or down** push button to change the set current. The display will return to the standby screen in a few seconds after the last push button activation.
- The units are amperes (amps) and volts. This display is very useful in understanding the system status. Anytime owner request assistance they should have these readings available, to provide accurate information to person assisting you .

As the electrodes wear or the water conditions change (conductivity) the voltage required to set current will increase. When this voltage reaches 24 vdc. it is at maximum output.

- **Electrodes Worn:** The electrodes are approaching end of life and should be replaced. Note, if the water conductivity is low this alarm may appear when the electrodes are still serviceable. This means that the water conductivity will need to be increased for the system to operate (contact distributor for additional if required). (see section 10)
- If the “electrodes worn” continues for five minutes the system will then display:

• **Ionize Error:**

IONIZE= – 0.00 A
ELECTRODES WORN

This indicates that the system “**can not**” provide the requested current. At this point the operator should review the diagnostic display and record the voltage and current. If the unit is still indicating current, then one may decide to delay changing the electrodes and if the water conductivity improves, the system will reestablish the set current. Even with an alarm error on the display the controller will continue to provide the current that 24 vdc will provide.

Audio Alarm:

- Alarm will intermittently beep when the controller cannot produce requested (set) current. If the alarm conditions continues for 5 minutes, alarm will then change to continuous alarm.
- The audio alarm can be silenced by pushing the **up or down** push button for three seconds.

CAUTION

Do not operate the IonGuard System without water in the system and the pump operating. Disconnect power before servicing. Drain system if unit is out of service for extended period of time or in freezing temperatures.

We recommend that you keep this operational manual near the system being treated for reference.

Your Triangular Wave Technologies IonGuard Purification System is manufactured in the USA with premium electronic components. No periodic maintenance is required. The front panel display indicates the operational status of the system. The indicators will not require replacement. IF the indicators are not correct, check the AC power and the wire to the electrodes.

The IonGuard System is designed to give you many years of trouble free water system care; however, if a problem does occur, the equipment and chemical trouble shooting guides below should help you correct the situation. If the problem persists, contact your TWT Distributor or Triangular Wave Technologies, Inc.

IF	DO
Low Copper Reading	Increase set current
Low Copper Reading with Control Unit Full On	Clean or replace electrodes
High Copper Level	Decrease set current
Display is Inoperative	Check power to system
Status Lights Inoperative	Check power to system
"T-Housing" Water Leaks	Tighten electrode assembly
Electrodes Worn	Check water flow (water must flow through system) replace ionization elements
Alarm Signal	Turn off power. Check electrode assembly & connection cord for short or disconnect
Ionize Error	Electrodes are nearing their useful life. Order replacement electrodes.
Standby Signal	See Section 7

SECTION 12 INSTRUCTIONS FOR THE USE OF TWT® DEPOSIT CONTROL TECHNOLOGY

TWTDCI-5C8-377 • TWTDCI-5C8-378 • TWTDCI-5C8-379 integrated deposit control and ionization treatment system



Introduction . . .

The Triangular Wave System is a technologically advanced method for the treatment of hard water and its effect on fluid based applications. The system is non-chemical by design and is suitable for all applications requiring hard water treatment.

Operating Principals . . .

The signal from the Triangular Wave System circuitry flows to a solenoid coil wound around the pipe treating and conditioning the fluid going through it. The signal in the coil develops the modulated electrical field that immediately conditions the water. The field penetrates the piping to its center, acting on the passing water and the dissolved minerals and particles in the water. The conditioning effects on the water are long lasting and last down stream.

TWT Deposit Controller / Solenoid Coil Terminal Hookup

The controller is supplied with a wiring kit and a strain relief connector for the solenoid coil wires. This strain relief will provide a water resistant seal for the two coil wires. You should rotate the compression ring counter clockwise to release pressure on the seal. Feed the two wires through the provided holes and tighten the compression ring. Connect the two wires to the coil terminals in the controller housing as illustrated. The systems are provided with an alarm relay, which may be used for external alarms. The relay contacts are rated 5 amps @ 120 vac. The contacts are isolated from the control circuit and are single pole double throw. If an external alarm is desired it may be connected to barrier terminals. (Refer to Figure B)

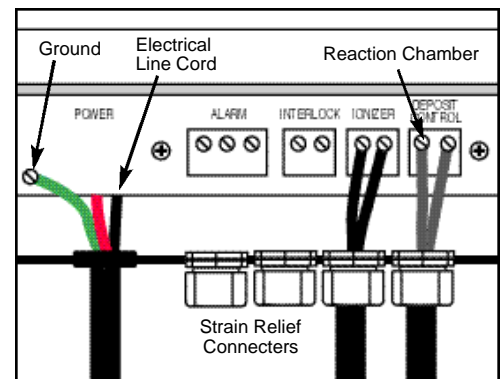
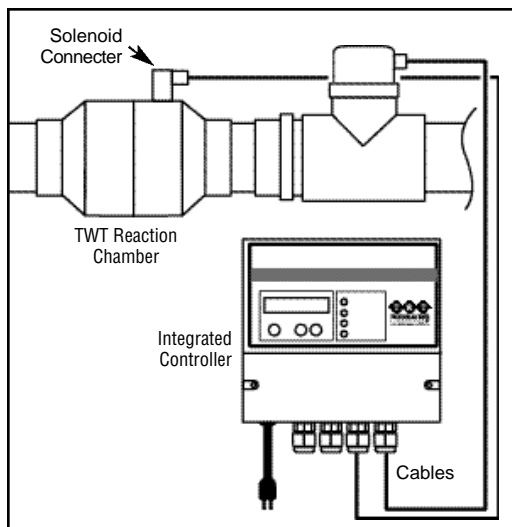

Diagram B



Factory Wrapped Wire Coil Reaction Chambers Application

To use in conjunction with the TWT Deposit Control Systems, Triangular Wave Technologies, Inc. has developed a line of factory-wrapped wire coil Reaction Chambers to address magnetic pipe environments. Typically, wire coil cannot be installed on any magnetic pipe, such as steel, galvanized steel, ductile iron, or cast iron. If a coil is applied to such a pipe, the pipe becomes a shield and prevents the wave energy from entering the fluid path. TWT Reaction Chambers solve this problem by providing an easily installed section of non-magnetic pipe to provide the proper pipe material for the Deposit Control System to work as designed. TWT Reaction Chambers are fully sealed, protecting their layers of factory-wrapped coil.

The TWT Reaction Chamber is part of the patented TWT Deposit Control Technology. The Reaction Chamber provides a chamber through which the water flows and is exposed to the triangular wave signal that lies at the heart of the deposit control technology. As the

fluid passes through, it is treated and then carries that treatment downstream, to condition the rest of the plumbing system, non-chemically and reliably.

When you have purchased a reaction chamber with cable and connectors with your controller unit, the correct strain relief connector for the controller is furnished with the cable for the reaction chamber. The strain relief connector on the controller (pipe solenoid) should be removed and replaced with the strain relief connector provided with the reaction chamber cable. The two wires should be connected to the coil terminals in the controller housing as illustrated.

The TWT deposit control systems have minimal maintenance requirements and no moving parts. The TWT deposit control systems should remain powered on all of the time. The control panels have indicator lights (see diagram) and alarm circuits to show problems caused by external forces such as damage to the coil, or insulation or damage to the electrical connection. The alarm circuit may be connected to your building control system, if desired.

The TWT deposit control systems are designed to remain on continuously provided there are no external interruptions, e.g., power outages), protecting equipment from scale, bio-film and corrosion. This is especially important for the equipment that is idle. Of course, the system can and should be disconnected from the power source when being directly handled for installation, removal, seasonal shutdown, or for other major equipment repair.

Recommended twice monthly Inspections:
 The deposit controller, reaction chamber, and fittings should be inspected visually for possible damage. In addition, the control panel has the built-in capacity for providing a 110-volt status signal in case th system output is interrupted.

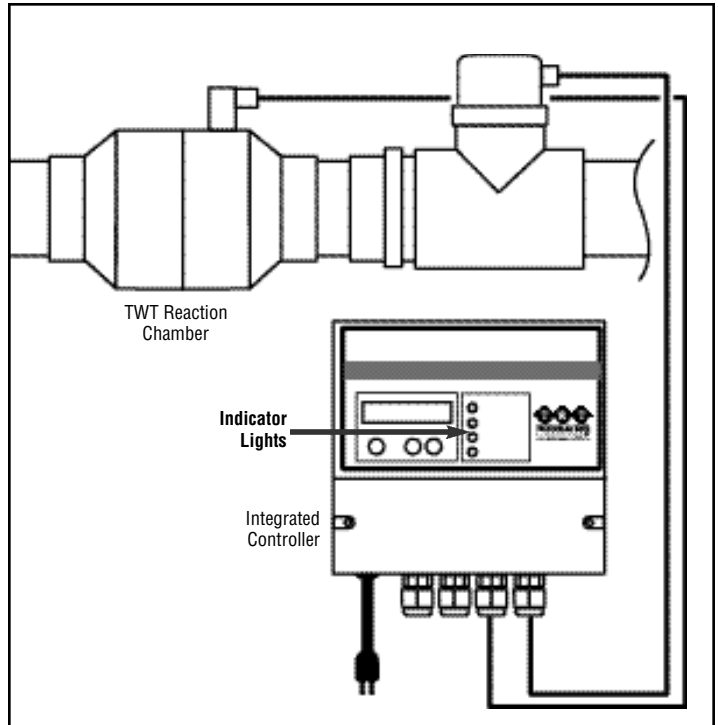

Indicator Lights

- Power On
- Coil Energized
- System Fault Error
- Push to Test

On the TWT Deposit Control Integrated Treatment System: If the deposit control reaction chamber is not connected the red light will show solenoid fault:

If TWT® deposit control system faults, contact dealer or TWT, Inc. for technical assistance.

Distributed by

WARRANTY

Product Warranty

All components of the Triangular Wave Microprocessor Deposit Control Systems are covered by a Five (5) Year Warranty provided that:

1. No modifications are performed on the unit;
2. The system is installed as recommended by Triangular Wave Technologies, Inc. and
3. There is no modification or change of installation without prior consultation with Triangular Wave Technologies, Inc. or its agents.

In the unlikely event that the unit becomes non-functioning, e.g., the “power” light and/or the “coil energized” light are not receiving the signal & are not lit, please return the unit for replacement to the place of purchase, with proof of purchase information.*

The Triangular Wave System does not affect the potability or the natural mineral content of the water, as there is no direct contact with the water. Triangular Wave Technologies, Inc., therefore, accepts no responsibility for water quality..

Performance Warranty (90 Days)

Triangular Wave Technologies, Inc. warrants that the Triangular Wave Microprocessor Deposit Control System will perform as indicated in this Owner's/ Installation Manual. If the product does not perform as indicated, the unit may be returned within 90 days from the invoice date for a refund of the purchase price, less the direct cost of shipping, installation.* Customer agrees that Triangular Wave Technologies, Inc. or its agents will be given access to the equipment for 90 days in order to monitor its performance, if desired, and/or to inspect the product and installation prior to any requested return authorization.

Under no circumstances shall Triangular Wave Technologies, Inc. or its agents be liable for consequential, special, or contingent damages or other claims or demands in excess of the purchase price of its products.

The Deposit Control System is non-invasive and non-chemical by design, and is suitable for nearly all applications requiring hard water treatment. The treatment process does not add anything to the fluid and should not cause damage to piping or equipment. The Deposit Control System is designed to remove scale; if piping or equipment has suffered corrosion prior to the installation of a TWT Deposit Control System, the removal of this scale may potentially reveal cracks/pinholes in this piping or equipment that had been held together by this scale.

If structural damage or corrosion is suspected to exist, appropriate measures should be taken to alleviate this condition prior to or in conjunction with the installation of the TWT Deposit Controller. Equipment owners must continue to be responsible in standard infrastructure and equipment maintenance procedures as recommended by the manufacturers of all piping and fluid fed equipment.

Triangular Wave Microprocessor Deposit Control System components should be inspected, upon receipt, for damage that might occur during shipment. The carrier and Triangular Wave Technologies, Inc. or its agents must be notified immediately if damage is found.** With proper care during installation and maintenance, the system will provide faithful service for many years.

*Triangular Wave Technologies, Inc. or its Authorized Representatives must be notified prior to any return for the proper Return Authorization, conditions and procedures.

**With the exception of Triangular Wave Technologies, Inc. represented products / components, which are covered by a separate standard warranty indicated in the products' Owners Installation Manual provided.

Triangular Wave Technologies, Inc. provides total support before, during, and after the installation.

Although Triangular Wave Technologies, Inc. has attempted to ensure the accuracy of the content of this publication, and its website, it is possible that they may contain technical inaccuracies, typographical, or other errors. Triangular Wave Technologies, Inc. assumes no liability for any error in its publications, and for damages, whether direct, indirect, incidental, consequential or otherwise.

Triangular Wave Technologies, Inc. provides these publications "as they are" without warranty of any kind, either express or implied, but not limited to implied warranties of merchantability or fitness for a particular purpose.

The published information in the publication and on the website are subject to change without notice. Triangular Wave Technologies, Inc. reserves the right to make changes in the products, systems, design and layout without notification to its customers.